

PNEUMAT[®] SYSTEM



■ SUITABLE FOR

Air, gases and vapours neutral



■ EXAMPLES OF USE

For the protection of:

- commercial and industrial plants
against too high supply pressure.
Pressure reducers are used, if within a piping system despite of varying pressures on the inlet side a certain pressure must not be exceeded on the outlet side.

- compressed air supply plants
- pneumatic control units
- pressure booster plants air-side
- shipbuilding industry and offshore plants



■ MATERIAL



■ SPECIFICATION



3/8" – 1 1/4"



– 10°C to + 95°C



Inlet pressure:
up to 50 bar
Outlet pressure:
1,5 to 10 bar
depending on version

■ APPROVALS

European Pressure Equipment Directive

TR ZU 032/2013 - TR ZU 010/2011

Requirements

PED 2014/68/EU

Classification society

Germanischer Lloyd	GL
Lloyd's Register EMEA	LR EMEA
American Bureau of Shipping	ABS
Bureau Veritas	BV
Russian Maritime Register of Shipping	RS

■ MATERIALS

Component	Material	DIN EN	ASME
Inlet body	Gunmetal	CC499K	CC499K
Outlet body	Gunmetal	CC499K	CC499K
Internal parts	Brass	CW617N	CW617N
Spring	Spring steel	1.1200	ASTM A228

■ VALVE VERSION

m	with diaphragm	High-quality, heat-resistant moulded elastomere, fabric-reinforced diaphragm. Pressure adjustment by means of spindle. Version completely made of metal. Balanced single seat valve, body with G 1/4" connection for pressure gauge on both sides.
----------	----------------	--

■ MEDIUM

G	gaseous	Compressed air and neutral gases
----------	---------	----------------------------------

■ TYPE OF LIFTING MECHANISM

0	without lifting device
----------	------------------------

■ OUTLET PRESSURE RANGES

SP	Standard version	Inlet pressure: up to 50 bar (size 1 1/4" up to 30 bar) Largest reduction ratio 10:1	Outlet pressure: from 1,5 to 10 bar
-----------	------------------	--	-------------------------------------

Fixed setting at a required outlet pressure against surcharge.

■ AVAILABLE NOMINAL DIAMETERS AND CONNECTION SIZES

Nominal diameter DN	10	15	20	25	32
Inlet female connection	3/8" (10)	1/2" (15)	3/4" (20)	1" (25)	1 1/4" (32)
Outlet female connection	3/8" (10)	1/2" (15)	3/4" (20)	1" (25)	1 1/4" (32)

■ TYPE OF CONNECTION INLET / OUTLET THREADED CONNECTIONS

f/f	Standard	Female thread BSP-P /Female thread BSP-P	DIN EN ISO 228-1 / DIN EN ISO 228-1
------------	----------	--	-------------------------------------

■ SEALS

NBR	Nitrile rubber	Elastomere diaphragms and seals	-10°C to +95°C
------------	----------------	---------------------------------	----------------

■ OPTIONS

Against surcharge	
Pressure gauges 36 and 40	Chapter Accessories

NOMINAL DIAMETERS, CONNECTIONS, INSTALLATION DIMENSIONS

Series 683: Connection, installation dimensions, ranges of adjustment

Nominal diameter	DN	10	15	20	25	32
Connection DIN EN ISO 228	G	3/8" (10)	1/2" (15)	3/4" (20)	1" (25)	1 1/4" (32)
Inlet pressure to	bar	50	50	50	50	30
Outlet pressure ¹	bar	1,5-10	1,5-10	1,5-10	1,5-10	1,5-10
Installation dimensions in mm	L	73	73	70	87	100
	H	100	100	120	165	175
	h	22	22	30	35	43
	SW1	27	27	36	44	54
	SW2	27	27	32	40	49
Weight	kg	0,5	0,5	0,8	1,4	2,0

¹Largest reduction ratio 10:1

MAIN DIMENSIONS, INSTALLATION DIMENSIONS

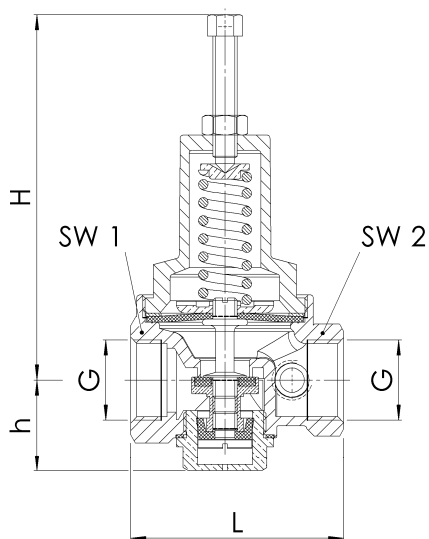

INDIVIDUAL SELECTION / VALVE CONFIGURATION

Series	Valve version	Medium	Lifting device	Outlet pressure	Nominal diameter DN	Connection type		Connection size		Seal	Options	Optional: fixed setting	Quantity
						Inlet	Outlet	Inlet	Outlet				
683	m	G	O	SP	20	f	f	20	20	NBR	Pressure Gauge 36		5
683	m	G	O	SP	32	f	f	32	32	NBR		4,0	1
683	m	G	O	SP		f	f			NBR			
683	m	G	O	SP		f	f			NBR			

■ CAPACITY CHART

Series 683:

Determination of the size and capacity

